



AMERICAN SPECIALTIES, INC.

441 Saw Mill River Road, Yonkers, NY 10701 (914) 476-9000

MODEL No: 0472

ISSUED: 1-87

REVISED: 9-04

PARTITION MOUNTED DUAL ACCESS SANITARY NAPKIN DISPOSAL

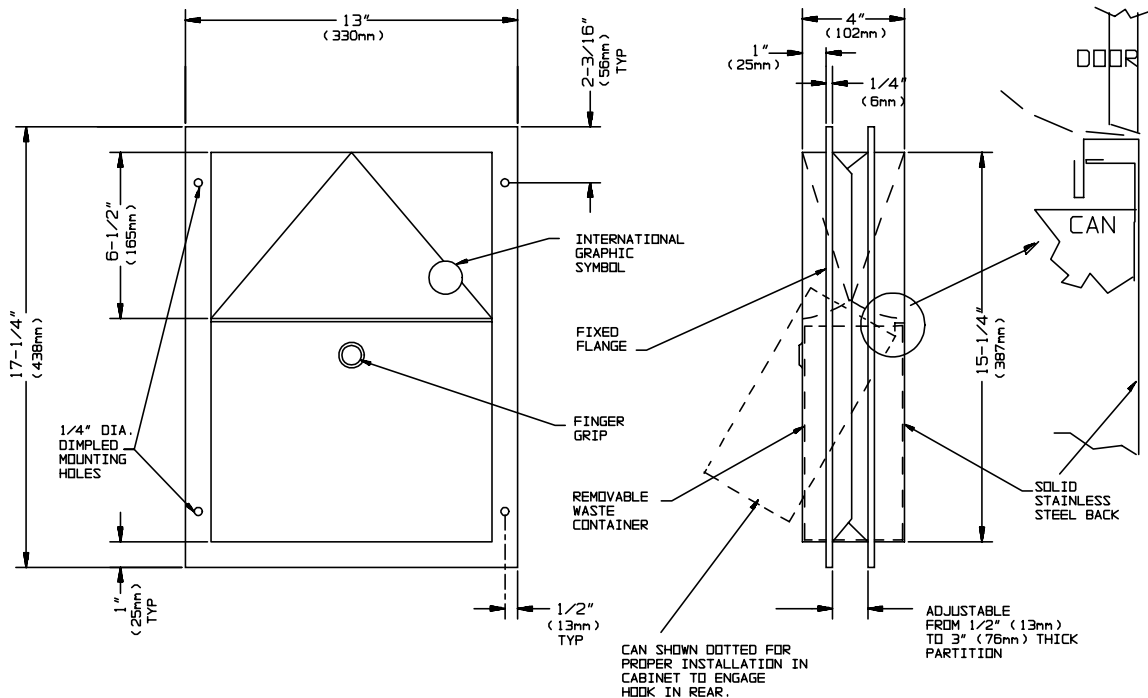

SPECIFICATION

Partition Mounted Dual Access Sanitary Napkin Disposal shall hold 1.5 gal (5.7 liters) of dry/solids waste and shall have doors and cabinet fabricated of alloy 18-8 stainless steel, type 304, 22 gauge. All exposed surfaces shall be N° 4 satin finish and be protected during shipment with a PVC film easily removable after installation. Doors shall operate independently and shall be attached to cabinet with a full length 3/16" dia. (5mm) stainless steel multi-staked piano hinge and shall be spring loaded to hold in closed position. International graphic symbol for waste disposal shall be affixed to doors. Structural assembly of body and door components shall be of welded construction. Face trim mounting flanges shall be of one piece construction 1" (25mm) wide with no welded miters and shall have square 1/4" (6mm) returns with an adjustability range for partition thickness of 1/2" (13mm) to 3" (76mm). Waste container shall be captured internally by full width Z- retainer and shall have fully hemmed-finger grip for service removal from one side only.

Partition Mounted Dual Access Sanitary Napkin Disposal shall be Model N° 0472 as manufactured by American Specialties, Inc., 441 Saw Mill River Road, Yonkers, New York 10701-4913

INSTALLATION

Unit is mounted on partition using N°10 self-tapping screws provided. For maximum usability and compliance with ADA Accessibility Guidelines, unit should be installed so that top of disposal door is between 33" (864mm) maximum above finished floor (AFF) and 24" (610mm) minimum AFF and 27" to centerline of cutout from rear wall. Note that cut-out is 3/16" (5mm) above cabinet door top and 13/16" (21mm) below top mounting flange top edge. One trim mounting flange adjusts for partition thickness of 1/2" (13mm) to 3" (76mm).

Partition Cutout Required is ...11-3/8"W x 15-5/8"H x 1/2" to 3" thick partition (289mm x 397mm x 13mm to 76mm)

OPERATION

Users push doors to deposit waste material. Doors are self-closing and operate independently and may be used simultaneously. Maintenance schedule determines waste removal cycle. Unit is emptied by removing bottom waste container and inverting over collection bag. Waste container is captured by internal angle to prevent inadvertent dumping and safety-edged finger grip provides convenient grip for service.

Accessory Specialties

AMERICAN DISPENSER

Desert Ray Products

WATROUS INC.